

Eyeball Indicator

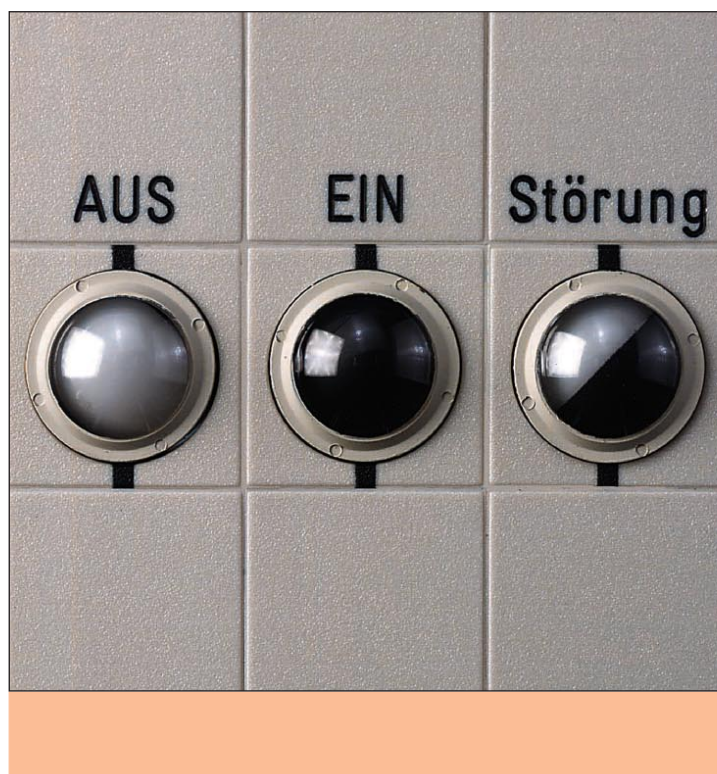

KM 24

KM 36



The products described in this brochure are intended for industrial use and meet the requirements laid down by the EU directive 73/23/EU (issued by the Council for Coordination of the Regulations of EU Member Countries regarding the electrical equipment for use within certain voltage limits, revised by directive 93 / 68 EU issued by the council).

The contents may be subject to modification for the purpose of technical improvement. The general regulations applicable to installation and commissioning must be observed. No warranty can be accepted.

Contents	Page
Application	4
Design and Principle of Operation	4
Technical Characteristics	4
Dimension Drawings and Diagrams	5

Application

The eyeball indicator is preferably used in situations that require visual simulation of the circuit or operating state of a device and indication of the fault position in addition to the ON and OFF positions. Eyeball indicators are particularly suitable for monitoring busbars and line disconnectors in complex transformer substations which are represented in the form of a mimic diagram of relatively small dimensions. As the eyeball indicator can be installed at the nodal point of the busbars, the mounting space can be reduced considerably. This space saving advantage increases even further with the number of busbars used in the system.

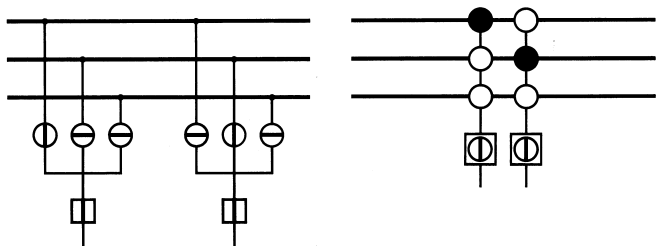

Eyeball indicators are also used by the chemical industry, for example, to monitor valves and slides in supervisory flow diagrams.

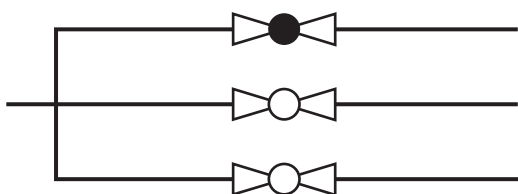

Design and Principle of Operation

The eyeball indicator has an electromagnetic drive which upon activation of the ON or OFF coil turns the rotating ball in the front of the housing by approximately 90 degrees to the right or left. At zero current, a simple spring system holds the ball in the exact centre position. The eyeball indicator is supplied with a coloured square or ring-form front plate. Eyeball indicators with a square front plate are intended for flush-type mounting, whereas ring-form eyeball indicators are intended for mounting in mosaic indicator boards. The diameter or side length of the front plate can be 24 mm or 36 mm.

The eyeball indicator is used for the representation of junction indicators, conductor run indicators (2 mm or 3 mm), earthing indicators, switch truck indicators, near-remote or local-remote indicators. The eyeballs and eyeball symbols are available in different colours.

Eyeball indicators of the type KM 36 r BEL, KM 36 q BEL and KM 36 m BEL are equipped with 2 holders for T 5.5. call lamps of the plug-in type. These illuminated eyeball indicators are used in systems where in addition to the mechanical position indication specific circuit states, for example, differential position information, must be indicated. The call lamps are inserted at the rear of the device.

Technical Characteristics

Exciter end

Type of current	Direct current
Nominal voltage	24 V, 48 V, 60 V, 110 V, 220 V
Continuous overload capability	1.1 V_{rated}
Response voltage	0.8 V_{rated}
Power consumption at U_n	1.0 W to 1.8 W

Lamp circuit

Supply voltage	60 V DC max.
Filament lamps	Type T5.5 24 V, 50 mA 30 V, 40 mA 48 V, 25 mA 60 V, 20 mA 70 V, 20 mA

General Characteristics

Type of protection	IP 40 (acc. to DIN 40050)
Test voltage	2 kV (VDE 0435 m/9. 72)
Ambient temperature range	-20 °C to +50 °C
Mechanical life	5 x 10 ⁴ operation
Mounting position	Any position
Weight (appr.)	160 g for KM 24 220 g for KM 36

Eyeball Colour

The standard colour for the colouring of the white ball for junction indication or the symbols for conductor run or earthing indication is black.

The following symbol colours are available at extra charge:

Yellow	acc. to RAL 1012 and RAL 1016
Red	acc. to RAL 2002 and RAL 3000
Blue	acc. to RAL 5010 and RAL 5012
Green	acc. to RAL 6002 and RAL 6010
Brown	acc. to RAL 8023
Green	acc. to RAL 7005

Additional symbol colours are available on request.

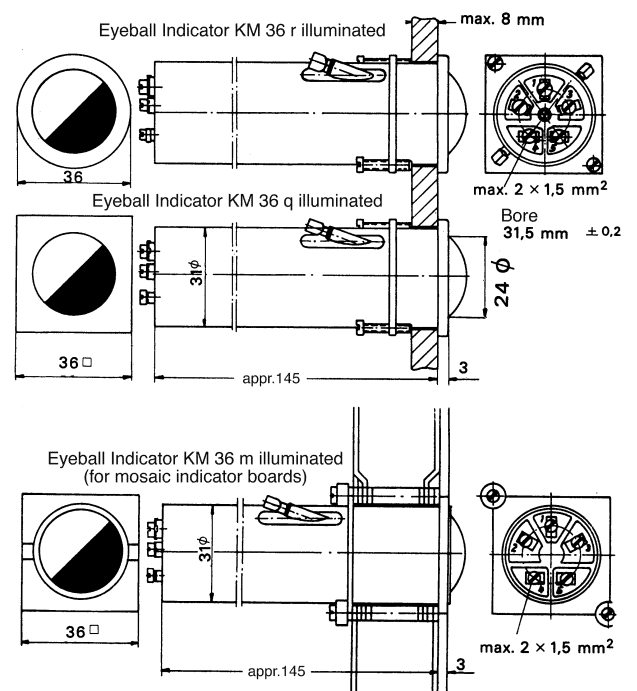
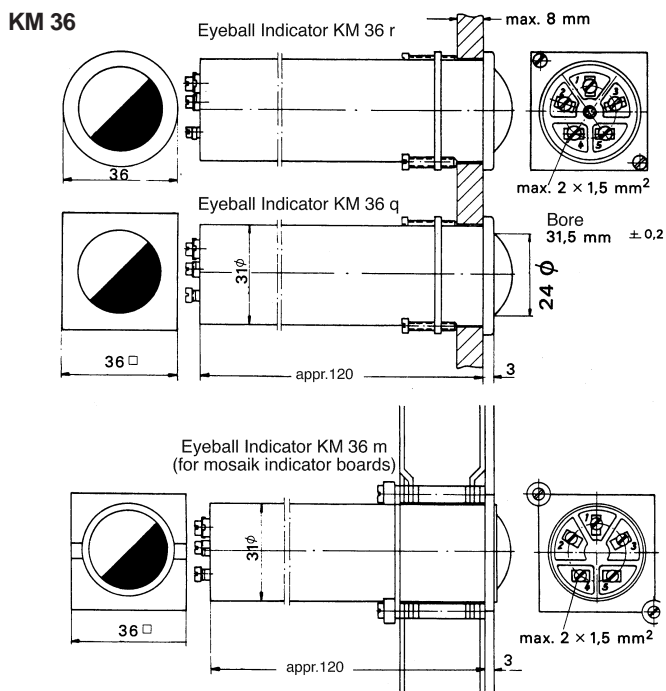
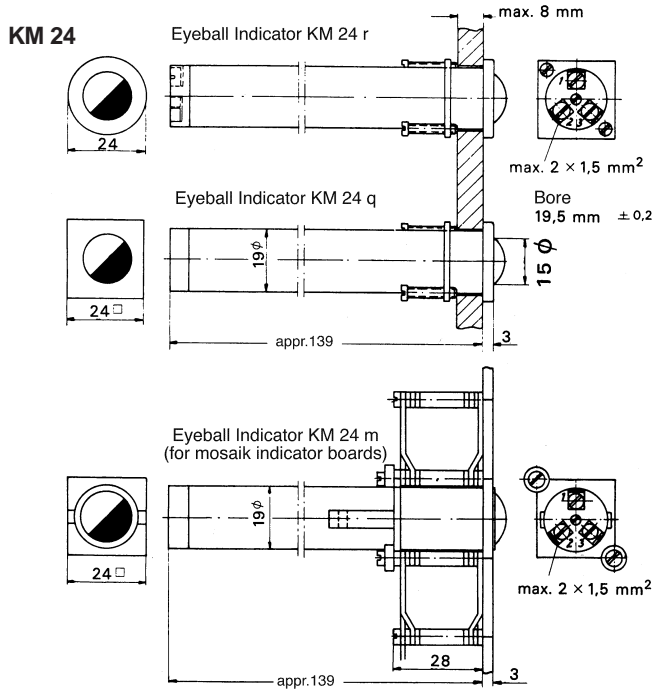

Diagrams

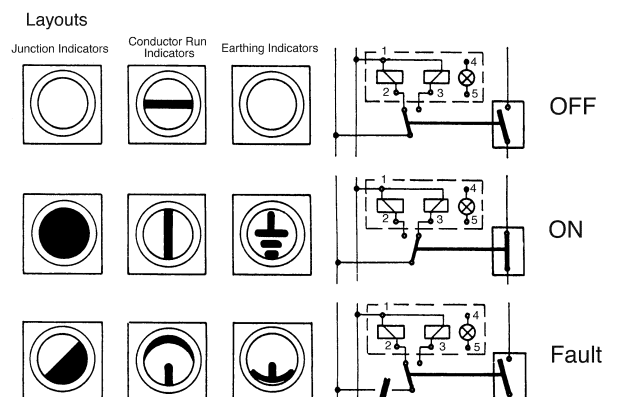
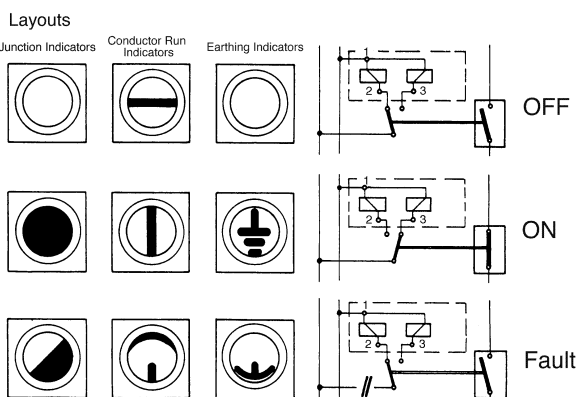

Representatives



INTERNATIONAL

Mauell AG
Furtbachstraße 17
CH-8107 Buchs/Switzerland
Tel. +41 (0)1/844 48 11
Fax +41 (0)1/844 44 56

Mauell GmbH
Brown-Boveri- Straße 8/12
A-2351 Wiener Neudorf / Austria
Tel. +43 (0)22 36/2 11 01-0
Fax +43 (0)22 36/2 11 01-30

Helmut Mauell B.V.
Postbus 89
NL-3840 AB Harderwijk / Netherlands
Tel. +31 (0)3 41/41 15 80
Fax +31 (0)3 41/41 15 81

Mauell Ltd.
P.O. Box No. 183
GB-Calne, SN11 9BZ, Wiltshire/Great Britain
Tel. +44 (0)12 49/81 20 46
Fax +44 (0)12 49/81 70 96

Mauell AB
Fredsforsstigen 22-24
S-168 66 Bromma/Sweden
Tel. +46 (0)8/98 60 05
Fax +46 (0)8/98 56 50
Telex 10 428

Mauell Corporation
31 Old Cabin Hollow Road
Dillsburg PA 17019/USA
Tel. +1717 432 86 86
Fax +1717 432 86 88

Helmut Mauell do Brasil Ltda.
Caixa Postal 54
06850-000 Itapecerica da Serra São Paulo/Brazil
Tel. +55 (0)11 79 47-17 77
Fax +55 (0)11 79 47-17 74

Helmut Mauell Pty Ltd
Level 11
100 Walker Street
North Sydney NSW 2060/Australia
Tel. +61 (0)2/9460 1855
Fax +61 (0)2/9460 0616

J. Lorente
Apartado de Correos 5
E-Las Rozas (Madrid)/Spain
Tel. +34 (0)9/16 30 07 50
Fax +34 (0)9/16 30 33 09

N.V. Rogelec S.P.R.L.
Nieuwevaart 101
B-9000 Gent/Belgium
Tel. +32 (0)9/2 25 54 06
Fax +32 (0)9/2 23 44 10

Ingeniørfirmaet K. Fritzbøger A/S
Kongevejen 79
DK-2840 Holte/Denmark
Tel. +45 45 41 45 31
Fax +45 45 41 45 32

Berggård Amundsen & Co. A/S
Postboks 25, Manglerud
N-0612 Oslo 6/Norway
Tel. +47 (0)22/68 10 00
Fax +47 (0)22/68 98 43
Telex 76 031

Fortum Engineering Ltd
Rajatorpantie 8, Vantaa
FIN-01019 Vantaa/Finland
Tel. +358 (0)9/8561 4436
Fax +358 (0)9/8561 4418

SERVICIOS Y SUMINISTROS S.A.
Casilla Correo 5239
RA-1000 Buenos Aires/Argentina
Tel. +54 (0)11/4796-12 80
Fax +54 (0)11/4791-86 65

Helmut Mauell GmbH
Magyarországi Iroda
H-1221 Budapest/Hungary
Tanító u. 19/A
Tel. +36 (0)1/424 00 97
Fax +36 (0)1/424 00 98

SULTAN INTERNATIONAL
P.O. Box 3486
Abu Dhabi U.A.E.
Tel. +9712/22 44 11
Fax +9712/22 44 55

KANA CONTROLS
GEN. TRADING & CONTRACTING CO. w.I.I.
Plot 28-30 Street No.31
Al Rai Industrial Area Kuwait
P. O. Box 25 59 3 Safat
13116 Kuwait
Tel. +9 65/47 41 3 7 3-76
Fax +9 65 /47 41 537

GERMANY

Helmut Mauell GmbH
Am Rosenhügel 1-7
D-42553 Velbert
Tel. +49 (0)20 53/1 30
Fax +49 (0)20 53/1 34 03

Helmut Mauell GmbH
Werk Weida
Papiermühlenweg 10
D-07570 Weida
Tel. +49 (0)3 66 03/4 80
Fax +49 (0)3 66 03/4 83 10